

ThermoFLUX

ThermoFLUX d.o.o., Bage br. 3, 70101 Jajce, Bosna i Hercegovina, Tel/Fax: 030-657-100
www.thermoflux.ba tinfo@thermoflux.ba

PELLET BOILER

INTERIO



USER AND MAINTENANCE MANUAL



DECLARATION OF CONFORMITY EU (DoC)

In accordance with ISO/IEC Guide 22 and EN 45014



Manufacturer : **ThermoFLUX d.o.o.**
Bage 3, 70101 Jajce
Bosna i Hercegovina

We declare under our sole responsibility that the product:

Name / Mark.....: Heating pellet boilers

Type / Model.....: INTERIO 22

To which this declaration relates, in accordance with the following normative documents:

Directives: MD 2006/42/EC
 LVD 2014/35/EU
 EMCD 2014/30/EU
 RoHS 2011/65/EU

Applied harmonized standards: EN 303-5:2012; EN ISO 12100:2010;
 EN 287-1: 2011, EN 61000-6-2; EN 61000-6-3; EN 60335-1; EN 60335-2-102;
 EN 62233; EN 50581

Other specified standards and specifications: EN 55014-1:2006/A2:2011;
 EN 55014-2:1997/A2:2008; EN 61000-3-2:2006/A2:2009; EN 61000-3-3:2008;
 EN 10204:2004; EN ISO 7000 :2004

Applied procedures for assessing compliance: Modul B-D

Limit values for emissions of combustion products (class): 4

Certificates that are issued: Report on type testing no. N. 338333

Accredited body: Istituto Giordano S.p.A
 Via Rossini, 2 - 47814 Bellaria-Igea Marina (RN) - Italia

We hereby declare that the above named product concept and method of preparation, in accordance with safety and security standards that comply with the above directives and standards.

In doing all operating conditions and terms of use in accordance with the attached instruction manual and technical documentation.

When only one change to the product which is not in agreement with us, this declaration loses its importance.

Last name, first name and title of signatory:

Jajce, 01.02.2017

Place and date of issue



Direktor Tomislav Ladan

Signature, Seal

Content:

1	Notes on the manual	7
1.1	Introduction	7
1.1.1	Easy and safe operation	7
1.1.2	Reading the manual	7
1.1.3	Technical changes	7
1.1.4	Copyright	7
2	Safety notes	8
2.1	Proper use	8
2.1.1	Basic principles	8
2.1.2	Using the boiler	8
2.1.3	Permissible fuel for the Interio boilers	8
2.1.4	Recommended wood pellets	8
2.2	Warnings and safety symbols used	9
2.3	Other risks of the side effects	9
2.4	Duty to inform	10
2.5	Safety devices	10
3	Installation and commissioning of the boiler	11
3.1	Conditions	11
3.2	Chimney and flue gas pipes	11
3.3	Minimum distances of the boiler from wall and objects	12
4	Functional description	13
4.1	General overview	13
4.2	Technical data:	14
5	Function of boiler	16
5.1	Overview of the controls and display and their basic functions	16
5.2	Principle of boiler operation	18
5.3	Schematic representation of the menu control	19
5.3.1	Clock adjustments	21
5.3.2	Adjustments of the programmed on and off mode	22
5.3.3	Boiler has possibility for programmed on and off mode during a day and this option is regulated on three ways:	22
5.3.4	LANGUAGE OPTIONS	24
5.3.5	STAND BY mode	24
5.3.5.1	STAND BY mode with installed sensor for water temperature	24
5.3.5.2	STAND BY mode with room thermostat connected	25
5.3.6	Option Buzzer	25

5.3.7 Filling of spiral dispenser26

5.3.8 STATE OF THE BOILER26

5.3.9 Technical settings.....26

5.3.10 FUEL TYPE.....26

6 Ignition and shutting down of boiler 27

6.1 Ignition27

6.2 Shutting down of boiler28

6.3 Boiler power adjustments28

6.4 Adjustment of water temperature in boiler29

6.5 Modulation.....30

6.6 Cleaning of FIRE-POT30

7 Cleaning and maintenance 32

7.1 Daily cleaning.....32

7.2 Cleaning the tube heat exchanger.....34

8 Connection options..... 38

8.1 Hydraulic schemes.....38

8.2 Scheme for electric connection41

9 Alarms..... 42

10 Instruction about safety removal and proper disposal of boiler..... 44

10.1 Disposal44

11 Guarantee 45

11.1 Guarantee period.....45

11.2 Guarantee terms45

11.3 Exemption from the guarantee45

12 Technical personal..... 46

1 Notes on the manual

1.1 Introduction

1.1.1 Easy and safe operation

This manual contains important information for proper and safe operation of the Interio boilers. Following these instructions you will avoid danger and repair costs, and also increase the operational life of the boiler.

1.1.2 Reading the manual

This manual must be read and applied by everyone who operates or works on the Interio boiler.

1.1.3 Technical changes

ThermoFLUX continuously develops and improves its boilers. The information in this version is correct at the time of going to press. All details in this manual on standards and regulations should be checked before use and should be compared with the installed boiler. We reserve the right to make changes which may then deviate from the technical details and illustrations in this manual.

1.1.4 Copyright

Written agreement is required from Thermo FLUX d.o.o. for any reprints, storage in a data-processing system or transmission by electronic, mechanical or any other means, for copies and publications, in whole or in part.

2 Safety notes

2.1 Proper use

2.1.1 Basic principles

Interio boiler was built in accordance with safety regulations. However, its use can result in the injury or death of the user and/or third part and in impairments to the boiler itself or to other material goods.

2.1.2 Using the boiler

Use the boiler only when it is in perfect condition. Use it properly, as described in this manual. Stay aware of the safety and of the dangers involved. Have any faults which can impair safety immediately fixed.

The boiler was designed to burn wood pellet and wood. The manufacturer will accept no responsibility for any damage resulting from improper use. Proper use includes maintaining the installation, operation and maintenance specified by the manufacturer. The user may only enter or change the operating values specified in this manual. Any other entries will affect the boiler's control program and operation, which can lead to a malfunction.

2.1.3 Permissible fuel for the Interio boilers

Only wood pellets and wood are permissible as fuel for the boiler. Wood pellets are pressed into a cylindrical shape. They consist of untreated sawdust from the wood processing industry as well as unprocessed forestry waste. They have a standardized diameter and length and very low water content.

2.1.4 Recommended wood pellets

Thermo FLUX d.o.o. recommends wood pellets with a diameter of 6 mm and a length of 10 - 30 mm.

- Other requirements on the fuel result from either standard O-Norm M 7135,
- DIN plus 51731,
- UNI CEN/TS 14961

Pay particular attention to the wood pellet quality.

2.2 Warnings and safety symbols used



DANGER OF ELECTRIC SHOCK.

Work on areas marked with this symbol may only be done by a qualified electrician.



WARNING!

Warning about a dangerous location. Work on areas marked with this symbol can lead to serious injuries or to extensive material damage.



CAUTION!

Hand injuries. Work on locations marked with this symbol can lead to hand injuries.



CAUTION!

Hot surface. Work on locations marked with this symbol can lead to burns.



Flammable materials

CAUTION!

Danger of fire. Work on locations marked with this symbol can lead to a fire.



CAUTION!

Frost danger. Work on locations marked with this symbol can lead to frost damage.



Notes on disposal.

2.3 Other risks of the side effects

Despite the precautions taken there are also certain risks of side effects:



DANGER OF CARBON MONOXIDE.

If the boiler is running during cleaning time may occur transmission of CO through the open door. Do not open the door longer than necessary.

2.4 Duty to inform

Reading the manual

Everyone who works on the boiler must have read the Use and maintenance manual before starting work and, in particular, have read the second chapter „Safety notes“. This holds especially true for persons who only occasionally work on the boiler e.g. when cleaning or maintaining the boiler. This manual must be kept ready to hand at the boiler's installation location.

Pay particular attention to the applicable local standards and guidelines.

2.5 Safety devices

Boiler is equipped with safety devices that in case of unexpected situations stop the power supply and thereby stop the operation boiler.

Boiler electronic regulation: operates directly and stops the operation of the boiler until it cools down.

* In case of the suction fan failure, failure of the motor for auger (doser), black out (if the blackout was longer than 10 seconds), an unsuccessful firing.

Fuse F 4 A 250V : Fast fuse , protects the boiler from large voltage changes of electricity and short circuits inside the boiler.

Safety thermo switch (STB) : intervenes by breaking the circuit in the boiler (automatically stops motor of the auger and exhaust gasses fan) if the boiler temperature reaches the limit of 95 °C.

Vacuum switch: intervenes in case of low underpressure in burner (open door, chimney jammed)

3 Installation and commissioning of the boiler

Commissioning system in the operation is performed by personnel authorized by ThermoFLUX Ltd or authorized seller.

Commissioning includes referral to operation with the basic operations and maintenance of the boiler. Authorized service for the first start, must control the functioning of the boiler at least during one full operating cycle.



Danger from material and body due to improper commissioning. If the commissioning is performed by unauthorized personnel, it may cause damage to the boiler and heating system.

3.1 Conditions

The following conditions must be fulfilled before the system is put into operation.

Turn OFF electrical power.

Check mechanical connections

Check that all components are properly connected
Check that all mechanical components are connected.
Check whether combustion chamber properly seated

Check hidraulical connections

Check whether the circulation pump and the mixing valve is properly connected.
Check whether the safety equipment properly connected.

3.2 Chimney and flue gas pipes

The chimney should be calculated and constructed in accordance with the EN 13384-1 standard.

The venting of flue gas must be done in accordance with all applicable laws including those related to dimensions of the chimney and materials used for its production. Flue gas channel should be made of adequate materials, such as steel tubes, with various sealing.

In any case, materials that could potentially catch fire, e.g. wooden planks, beams, cloth, should be adequately protected with non-combustible material. For the sake of parity of dimensions, chimneys that are round in shape of the inner part should have an advantage over the rectangular-shaped chimneys.

Too small inner zone can cause irregular flow from the boiler to the top which could lead to poor boiler performance and excessive exhaust gas production that discharges the exhaust gas to the environment. Gas flue pipe should be permanently installed and it would be good to make safety door which would enable the cleaning of inner parts, especially the horizontal parts.

Smoke pipe should be installed fixed. It would be good to leave safety gates that could do the interior cleaning, especially in their horizontal parts.

You should avoid as much as possible horizontal mounting parts. Horizontal parts must have a slope of at least 3% upwards.

Length of the horizontal part should be minimal and in any case not more than 3 meters.

ALL PARTS OF THE FLUE GASN PIPE NEED TO BE SECURED AND REPLACEABLE IN ORDER FOR INTERNAL CLEANING.

AVOID MULTIPLE HORIZONTAL DEVIATION AND ANGLES.

3.3 Minimum distances of the boiler from wall and objects

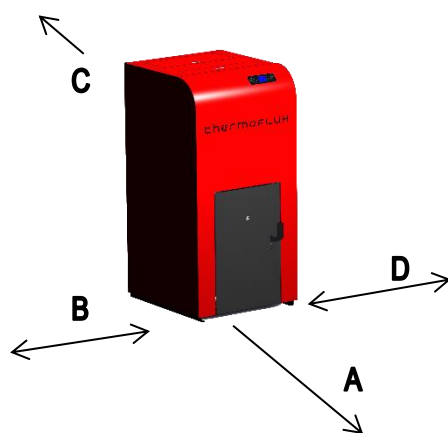

- A – minimum distance front - **100 cm**
- B – minimum distance from side - **30 cm**
- C – minimum distance back side- **30 cm**
- D – minimum distance from side - **30 cm**

i ThermoFLUX leaves itself the right to later perform changes without notice.

4 Functional description

4.1 General overview



Accompanying material

- Door key
- Power supply cable
- Instructions booklet
- Guarantee

4.2 Technical data:

		J.M	Interio 15	Interio 22	Interio 24
1	Wight	kg.	237	256	256
2	Power range	kW	5-15	7-22	7-24
3	Water content	L	33	40	40
4	Chimney draught	Pa	0,05-0,12	0,05-0,12	0,05-0,12
5	Out / return conection	ZOLL	R1	R1	R1
6	Flue gas temp (max. power)	°C	cca160	cca160	cca160
7	Work temperature	°C	55-80	55-80	55-80
8	Max work pressure	Bar	2,5	2,5	2,5
9	Height flue gas pipe (center)	mm	278	278	278
10	Depth	mm	785	785	785
11	Width	mm	610	610	610
12	Height	mm	1250	1250	1250
13	Flue gas pipe diameter	mm	80	80	80
14	Out / return height	mm	640/150	640/150	640/150
15	Pellet silo capacity	kg	50	50	50
16	El power consumption min/max	W	100/420	100/420	100/420
17	Min/max pellet consumption	kg/h	1,5-3,5	1,3-4,8	1,3-4,8
19	Permitted fuel	-	Pelet	Pelet	Pelet
20	Flue pipe conection		back	back	back

NOTE: A ground connection to the boiler body for high voltage protection (lightning strike, etc.) is mandatory. Otherwise the warranty on electrical components is not valid.

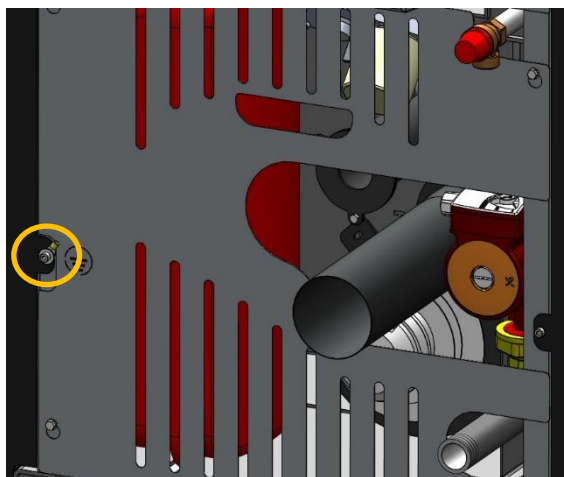

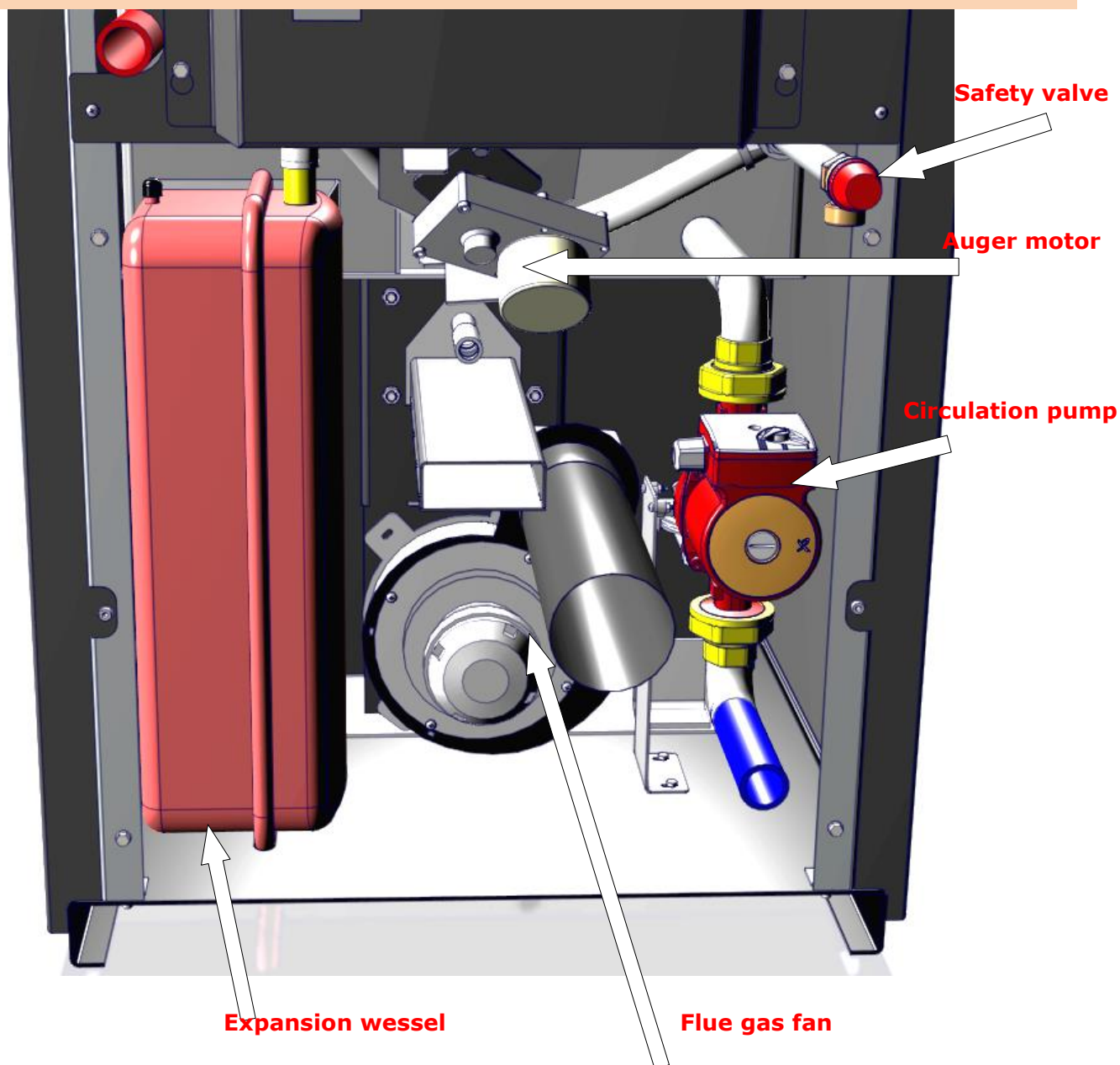

Back view :

1. Electro conections and equipment :
 - Power cable and switch
 - Room thermostat conection
 - STB - safety thermo breaker (switch)
2. Flue gas pipe 80 mm
3. Hidraulic conection 1".

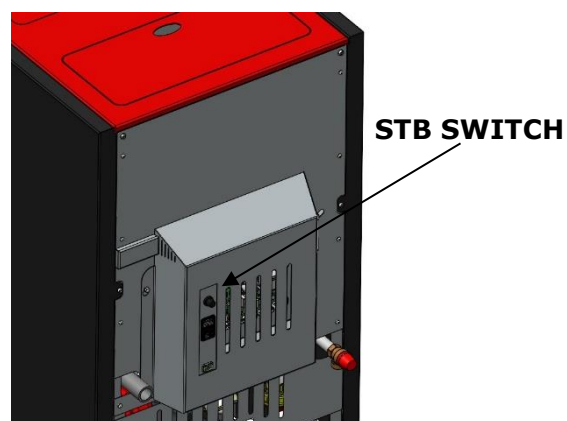

5 Function of boiler

5.1 Overview of the controls and display and their basic functions

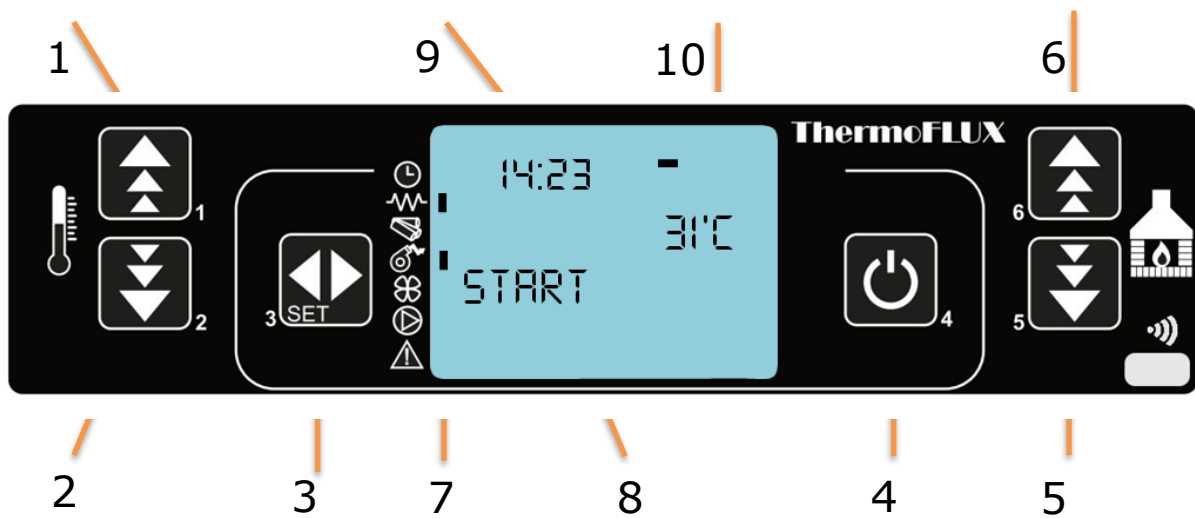

Button

Description

1 - 

Increasing temperature and program functions (adjusting days, time...)

2 - 

Decreasing temperature and program functions (adjusting days, time...)

3 - 

Changing - accepting program

4 - 

ON / OFF, program exit

5 - 







Decreasing power, navigate through the menu

6 - 

Increasing power navigate through the menu

7

When mark is visible

	Clock	• programmed ignit. active
	Heater	• heater active
	Pellet dosage	• auger active
	Smoke fan	• fan active
	Primary air fan	• fan active
	Circulating pump	• pump active
	Alarm	• alarm active

Display

8	Info
9	Clock
10	Water temperature indicator

Regulation on the boilers "Pelling" is most important electronic component. It is consisted of key controlling modul set under the cover of the boiler and controlling unit with display set on the front side of the boiler. With controlling unit it is possible to control functions of the boiler and also to check information about present state of the boiler.

Due to the possibilty to work in 5 (five) different powers, regulation can satisfy needs to increase or decrease heating by automatic adjustment of power.

If there is a need to increase power, this is registered by regulation and regulation gives a signal to increase power by adding more pellet as well as proportional increase of air flow in the burning basket.

When desired temperature is reached (need for heating energy is satisfied) regulation is decreasing power (modulates), or when room thermostat gives signal that set temperature is reached, boiler then goes into SHUT DOWN mode (if mode STAND-BY is ON)

5.2 Principle of boiler operation

Principle of the boiler operation is very simple.

When button for start is pressed boiler goes into IGNITION MODE. START is displayed, and after that PELLET IGNITION. Usually this phase lasts for 5-15 minutes depending on type of the boiler and pellet quality. At that point dosing system is activated, igniter and suction fan. Dispenser is making initial dosing of pellet into burning basket. At the same point igniter starts to ignite pellet and suction fan is on and is making necessary underpressure needed for combustion. When temperature sensor for flue gases detects that temperature in the chimney has reached necessary value, regulation then changes working mode of the boiler into FLAME STABILIZATION.

This phase (FLAME STABILIZATION) lasts for 2-3 min. (depending on the type of the boiler and in this phase igniter goes off. After flame stabilization, boiler goes into the normal working mode and changes power from power 1 to set power. On display is written WORK. On the right side set power is displayed and in the last

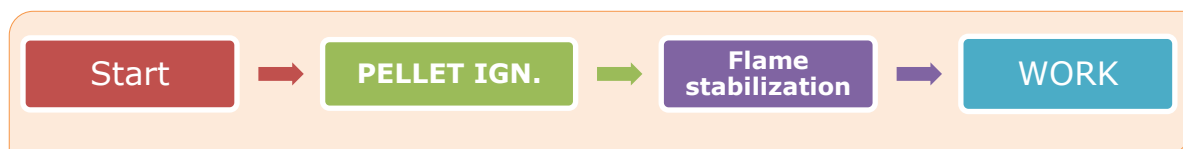

5.3 Schematic representation of the menu control

By pressing button SET we enter general menu.

MENU		VALUE	DESCRIPTION
MENU 01 SET CLOCK	SET	TABLE 1	TIME AND DATE ADJUST
MENU 02 SET CHRONO	SET	M-2-1 ENABLE CHRONO	PROGRAMED SWITCHING ON - OFF
		ON / OFF M-2-1-01 ENABLE CHRONO	
MENU 03 SELECT LANGUAGE	SET	HR-IT-EN-DE-FR-ES-PT	LANGUAGE SELECTION
MENU 04 MODE STAND-BY	SET	ON - OFF	ROOM THERMOSTAT MODE - SWITCH OFF BOILER (ON) , - MODULATION (OFF)
MENU 05 MODE BUZZER	SET	ON - OFF	BUZZER
MENU 06 LOAD INITIAL	SET	90 SEC	INITIAL LOAD OF THE PELLET
MENU 07 STATE STOVE	SET	WATER TEMP.; EQHAUST GASES TEMP.; EQHAUST FAN RPM.	STATE OF THE BOILER
MENU 08 SETTINGS TEHNIC	SET	ONLY FOR TECHNICAL PERSONAL	
MENU 09 FUEL TYPE	SET	PELLET - WOOD	FUEL TYPE SELECTION

BUTTONS 1 AND 2 - CHOOSE DESIRED
VALUE

BUTTONS 5 AND 6 - CROSSING
BETWEEN MENUS

BUTTON 3 (SET) - ACCEPT
BUTTON 4 (ON/OFF) - BACK

Table 1

MENU 01 SET CLOCK	MENU 01 MONDAY DAY 08	PON - NED	DAY ADJUSTMENT
	MENU 01 TIME CLOCK :33	00-24	HOUR ADJUSTMENT
	MENU 01 MINUTES CLOCK 30	00-59	MINUTE ADJUSTMENT
	MENU 01 DAY CLOCK 30	01-31	DATE ADJUSTMENT
	MENU 01 MONTH CLOCK 13	1-12	MONTH ADJUSTMENT
	MENU 01 YEAR CLOCK	00-99	YEAR ADJUSTMENT

Table 2

MENU 02 SET CHRONO									
M-2-1 ENABLE CHRONO	M-2-2 PROGRAM DAY	ON/OFF M-2-2-01 CHRONO DAY	06:00 M-2-2-02 START 1 DAY	10:00 M-2-2-03 STOP 1 DAY	15:00 M-2-2-04 START 2 DAY	19:00 M-2-2-05 STOP 2 DAY			
	M-2-3 PROGRAM WEEK	ON/OFF M-2-3-01 CHRONO WEEKLY	06:00 M-2-3-02 START PROG- 1	14:00 M-2-3-03 STOP PROG- 1	ON / OFF M-2-3-04 MONDAY PROG- 1	ON / OFF M-2-3-05 TUESDAY PROG- 1	ON / OFF M-2-3-06 WEDNESDA PROG- 1	ON / OFF M-2-3-37 SUNDAY PROG- 4
	M-2-4 PROGRAM WEEK-END	ON/OFF M-2-4-01 CHRONO WEEK-END	06:00 M-2-4-02 START 1 WEEK-END	12:00 M-2-4-03 STOP 1 WEEK-END	16:00 M-2-4-04 START 2 WEEK-END	22:00 M-2-4-05 STOP 2 WEEK-END			
M-2-1-01 ENABLE CHRONO									

BUTTONS 1 AND 2 - CHOOSE DESIRED VALUE

BUTTONS 5 AND 6 - CROSSING BETWEEN MENUS

PROGRAM WEEK
(M-2-3)
POSSIBILITY OF 4 (four) TIMES FOR SWITCHING ON OR OFF

5.3.1 Clock adjustments

Clock adjustments can be done on following way:

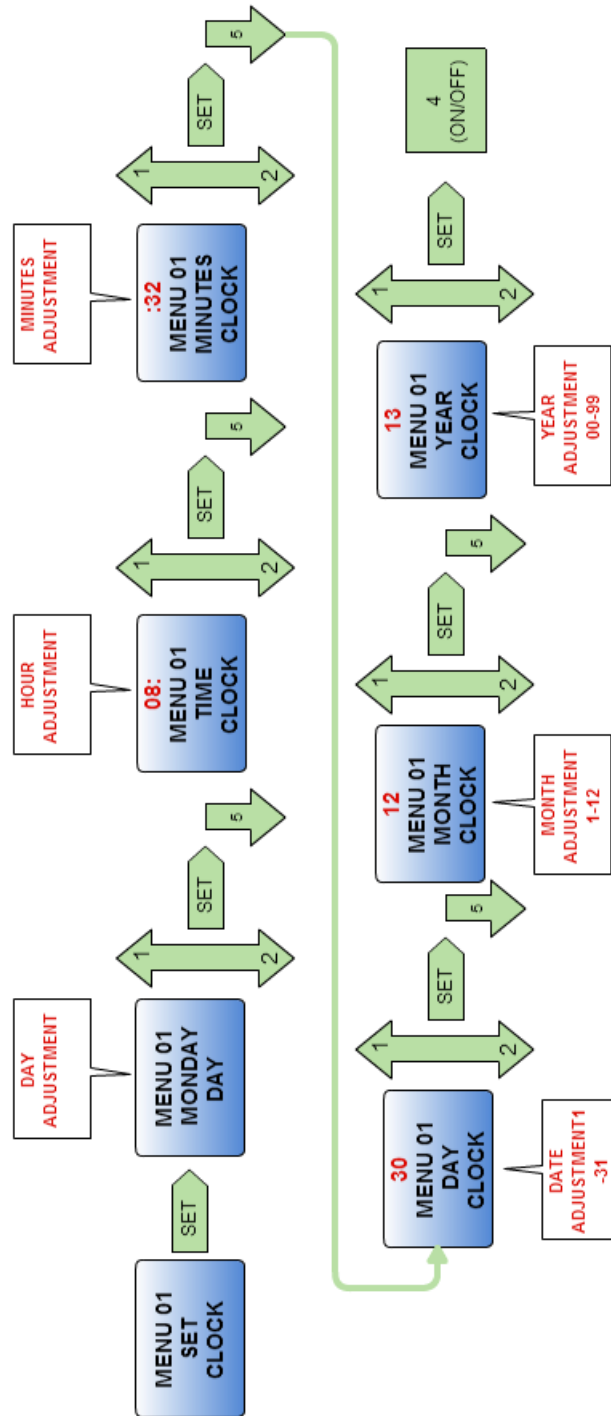

5.3.2 Adjustments of the programmed on and off mode

5.3.3 Boiler has possibility for programmed on and off mode during a day and this option is regulated on three ways:

1. **DAY PROGRAM**, in this mode we can set 2 (two) different times for ignition and shutting down of the boiler. This applies to all days in the week. (Scheme 2)
2. **WEEK PROGRAM**, in this mode we can set 4 (four) different times for ignition and shutting down. In this mode, we can choose day in the week (MON-SUN) in which we want boiler to work for each program (Scheme 3)
3. **SUN-SAT PROGRAM**, in this mode we can set 2 (two) different times for ignition and shutting down, but only for SATURDAY and SUNDAY. (Scheme 4)

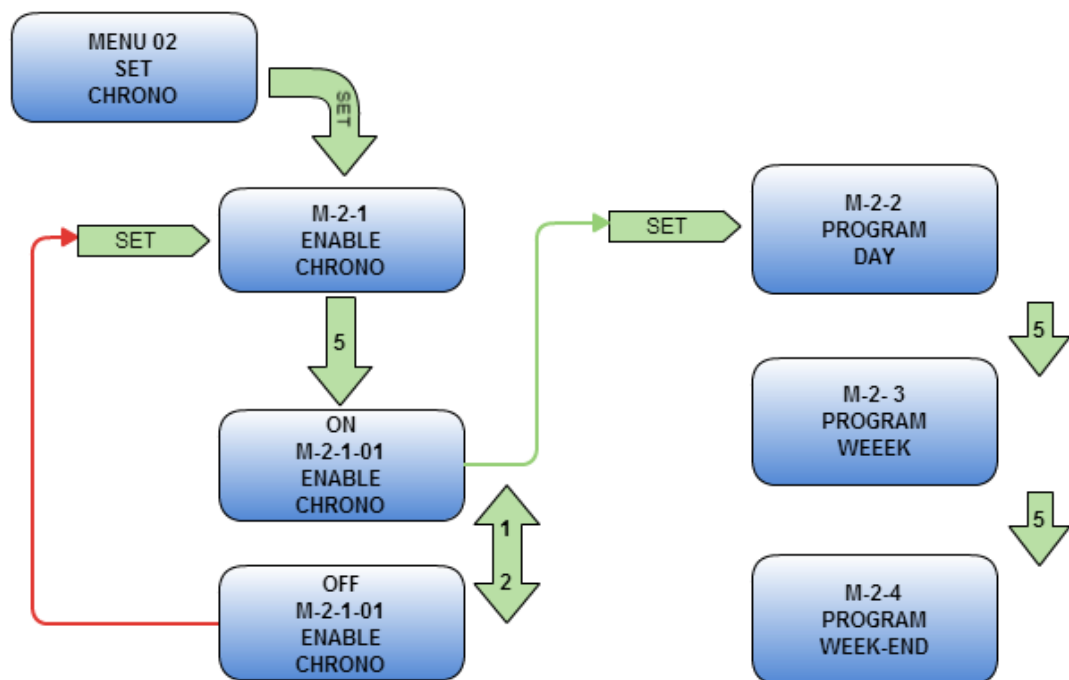

Scheme 1.

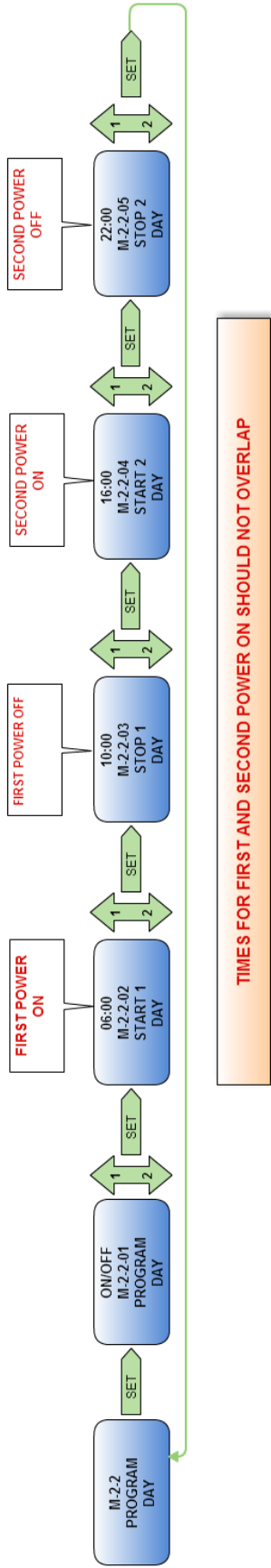

Schema 2.

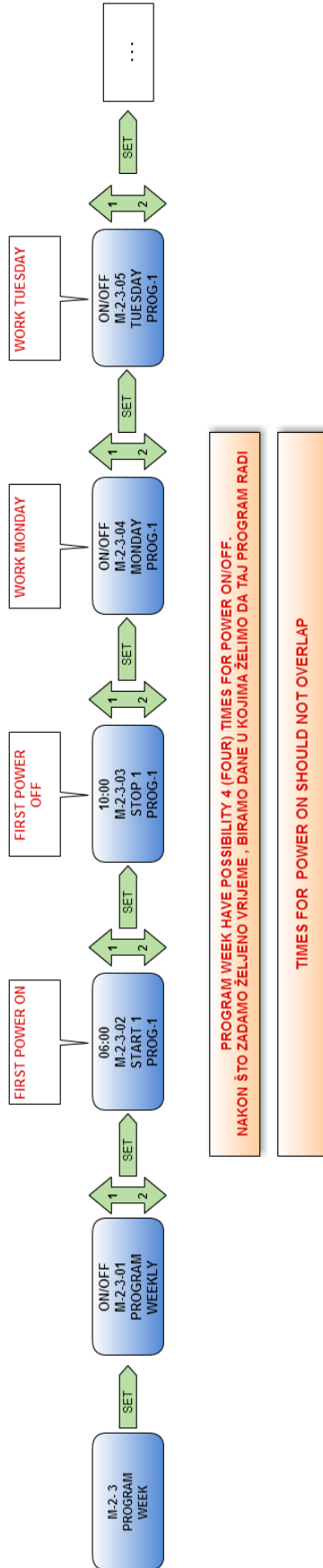

Schema 3.

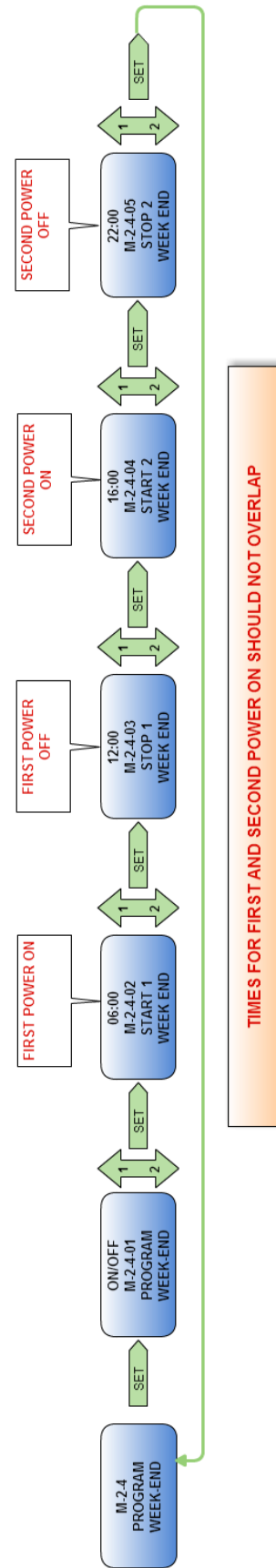

Schema 4.

5.3.4 LANGUAGE OPTIONS

Language settings are adjusted by pressing the SET button, and after that by pressing of button 5 or 6 we choose option MENU 03-LANGUAGE.

By pressing of the SET button language menu is opened (italian, english, german, french, croatian...) in which we can choose desired language by pressing button 1 or 2.

When desired language is chosen, confirmation is to be done by pressing button SET.

Returning back is done by pressing button 4 (ON/OFF)

5.3.5 STAND BY mode

STAND BY is used in two ways..

- In the case that boiler shuts down because desired temperature is reached (set ON) ,
- In the case that boiler modulates when desired temperature is reached (set OFF).

Function STAND BY can be set ON or OFF on following way:

STAND BY mode is activated by pressing button SET, and afterwards by pressing buttons 5 and 6 we choose desired item in the MENU 04 – STAND BY MODE.

By pressing SET we are opening options ON or OF (chosen by pressing of buttons 1 or 2, and confirmed by pressing of button SET).

5.3.5.1 STAND BY mode with installed sensor for water temperature

i Connection for room thermostat is delivered overbridged, which means that contact is closed.

1. FUNCTION STAND-BY SET ON

In the case that function STAND-BY is activated (ON), boiler will shut down when desired temperature is reached and above by 2 degrees C, and after 2 minutes of time pause (set in factory) TON-WAITING COOLING is displayed. If temperature do not decrease below set temperature during 4 (four) minutes, on display is written TON-REQUEST WAITING.

When temperature of the water in boiler is below set temperature by 2 degrees C, boiler will start again with ignition mode and it will work on set power.

2. FUNCTION STAND-BY SET OFF

In the case that function STAND BY is not activated (OFF) , and that connection for the room thermostat is not overbridged, boiler will always work in power 1 no matter which power is set.

In the case that function STAND BY is not activated (OFF), and connection for room thermostat is overbridged (set in the factory) boiler will work in the power chosen by the user, and when desired temperature is reached will go into modulation mode. Boiler will shut down only if the temperature in the boiler is 80 degrees C, and will start again when temperature drops down below desired temperature.

5.3.5.2 STAND BY mode with room thermostat connected

1. FUNCTION STAND-BY SET ON – room thermostat shuts down boiler

When room thermostat sends signal that desired temperature in the room is reached (contact is open/temperature is reached) boiler will shut down after 2 minute (factory settings- in the case that temperature in the room changes all to prevent constant turning on and off of the boiler) on display is written **tOFF-WAITING REQUEST**.

When room thermostat gives signal that room temperature is low (contact closed/ temperature needs to be reached) boiler will start ignition and on display is written **tON**.

Remark: Boiler functioning primarily depends on temperature of the water inside of boiler and factory settings inserted. If boiler is in state of **WAITING COOLING** (water temperature is reached), eventual request of the thermometer will be ignored.

2. FUNCTION STAND-BY SET OFF – room thermostat gives signal to the boiler to work in POWER 1

In the case that function STAND BY is not activated (OFF) boiler will work in power chosen by the user and when desired temperature is reached boiler will modulate (will not shut down but working power will change to lowest). Boiler will shut down only if temperature of the water in the system is 80 degrees C, and on display is written **WAITING COOLING**. Boiler will start again when temperature in the system drops down below set temperature.

5.3.6 Option Buzzer

BUZZER is used in the case that user want to hear sound signal from the boiler in the case of activated alarm (set ON), or without sound signal (set OFF).

Option BUZZER is activated by pressing of button SET, and after that with buttons 5 or 6 we choose item **MENU 05- OPTION BUZZER.**

By pressing of the button **SET** choice **ON** or **OFF** is opened (with buttons **1** or **2** we are selecting option and confirmation is done by pressing **SET**).

5.3.7 Filling of spiral dispenser

Filling of spiral dispenser with pellet is done when pellet is loading for the first time or in the case of empty silo. Process of filling of spiral dispenser is set to 90 seconds .

Filling of spiral dispenser is done by pressing of button SET, and after by pressing buttons 5 or 6 we choose **MENU 06-FILLING OF SPIRAL.**

Filling os spiral is activated by pressing of button SET.



Prior to start up of the boiler, check combustion chamber. There is a big possibility that there are some leftovers from pellet in it while spiral dispenser was filled. Combustion chamber needs to be empty and then ignition process can be initiated.

5.3.8 STATE OF THE BOILER

State of the boiler is only of informational character and its purpose is to give us information about condition of the boiler. On display information is randomly changed about water temperature in the boiler, flue gasess temperature, fan RPM, etc. To enter this option press SET, after that with buttons 5 or 6 we choose **MENU 07 – STATE BOILER.**

5.3.9 Technical settings

TECHNICAL SETTINGS are foreseen for authorised personnel only.

5.3.10 FUEL TYPE

FUEL TYPE is part of the menu where user is changing information about used fuel type. By default fuel is SET to PELLETT, and in the case that we want to use wood, it is necessary to change this option to WOOD.

Selection of thy fuel type is done by pressing SET, and after that 5 or 6 we choose **MENU 09 – FUEL TYPE.**

By pressing SET,option for desired type of fuel is opened (**PELLET** or **WOOD**).Selection is made by buttons 1 or 2. After choosing of fuel type, confirmation of selection is done by pressing button SET.

6 Ignition and shutting down of boiler

Ignition sequence and description of regulation

Basic function of the regulation is to secure reliable ignition of used fuel, optimal conditions for combustion and controlled sequence for shutting down. Depending on working power, and complexity of the heating system, parameters are read and controlled differently. Some of the most important ways of working are described with relevant values.

Before start up following things needs to be checked:

- Silo needs to be filled with pellet
- Silo doors needs to be closed
- Combustion chamber/basket needs to be cleaned
- Ash pot needs to be clean
- All doors on boiler needs to be closed
- Boiler must be connected to electric source - 220 V, 50 Hz

6.1 Ignition

Press and hold button 4  for 3 (three) seconds. Boiler will start with ignition.



START will be displayed, on the left side of display we see that igniter and suction fan are activated. Mark **TON** is showing that room thermostat is connected or overbridged on connection for room thermostat (default).

After that, on display we have text LOAD PELLETT and on the left side we see that feeding of pellet is activ.



After ignition of pellet, and after temperature of flue gasses raise on value of 55 °C, regulation receives signal that fire is on and boiler continues to work with set values.

6.2 Shutting down of boiler

Press and hold button 4  for 3 (three) seconds. On display it is written **CLEANING FINAL**. Suction fan is working on maximum, feeding of pellet is stopped.



6.3 Boiler power adjustments

During working phase, it is necessary to set working power in which we want boiler to work.

Adjustments of the working power is possible in the range from 1-5, and selection of desired power is done by buttons 5 or 6 (*1). On upper line it is written **WORK** and set power (*2), and present working power sign is blinking on lower line on the right side (*3).

Power 1 is lowest and power 5 is highest power.

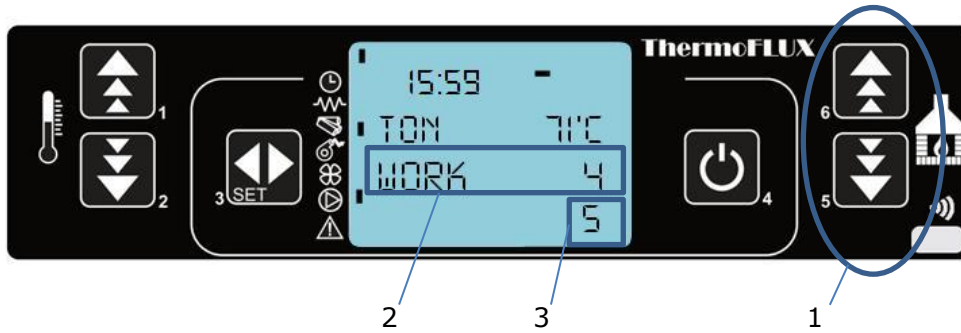

Regulation on the boiler is set in the way to modulate (power goes into lowest one) it's work when 4 C is reched below set temperature – **read 6.5 Modulation**

6.4 Adjustment of water temperature in boiler

Adjustment of water temperature in the boiler is done by pressing button 1 or 2 (*1). Temperature can be set in range from 55 °C to 80 °C (*2). These are factory settings and it is not possible to set lower or higher temperature then above mentioned.

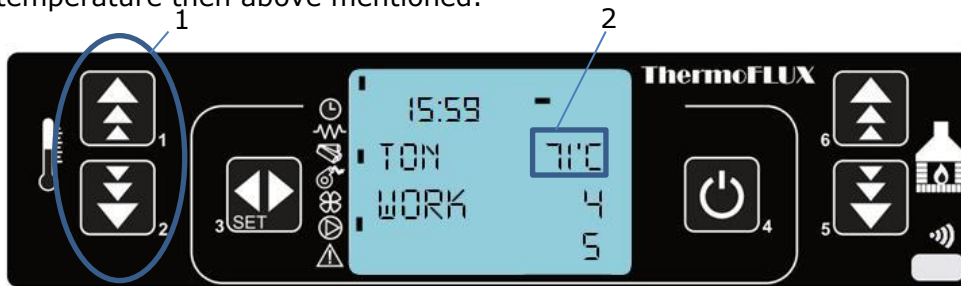

6.5 Adjustment of sanitary water temperature

Adjustment of sanitary water temperature in the boiler is done by pressing button 2 first, then set the temperature between 55°C and 80°C with the buttons 1 and 2. After selecting the desired temperature it is necessary to confirm with SET button. These are the factory settings and it is not possible to set lower or higher temperature of the sanitary water.



6.6 Modulation

When water temperature in boiler is near to set value regulation begins to modulate its work and changes power to lowest. Modulation starts 4 °C below set temperature.

EXAMPLE: We have adjusted water temperature on 73°C and power 5, regulation will work in power 4 when temperature is 70°C, on 71°C boiler will work in power 3, on 72°C power is 2 and when 73°C is reached then boiler is working in power 1. **MODULATION** is displayed.



If temperature rises above set temperature by 2 °C, boiler will be shut down automatically and on display will be written **WAIT COOLING**.



When temperature in the boiler decreases for 2 °C below set temp. regulation will start process of ignition again.

6.7 Cleaning of FIRE-POT

During its work boiler has set timer for cleaning of combustion basket (fire-pot) after certain time. This phase is shown on display and work of the boiler is set to lower power, and suction fan is working on maximum for certain period of time as set in the factory.



When cleaning phase is finished, boiler will continue to work and power will be set on power chosen before.

7 Cleaning and maintenance

To secure proper work of the boiler, cleaning and maintenance is necessary.

Cleaning can be divided in three stages :

- **Daily**
- **Weekly**
- **Monthly**

7.1 Daily cleaning

- Turn the boiler off and wait until it has been cooled.
- Open the boiler door.
- Using safety gloves clean combustion deposits out of the firebox to ensure a smooth flow of air necessary for efficient combustion. Using safety gloves take the firebox out and empty its content into a fire-resistant container.
- Clean the holes in the firebox with an appropriate screwdriver (if needed) .
- Put the firebox back onto the bearing making sure it is properly seated on the heater.
- Close the door before ignition.

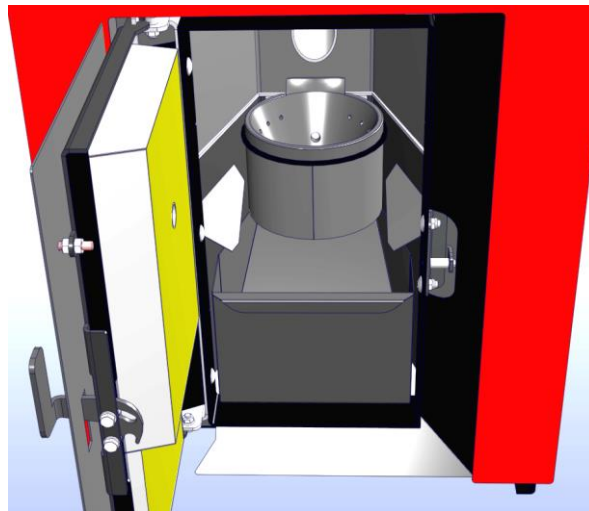

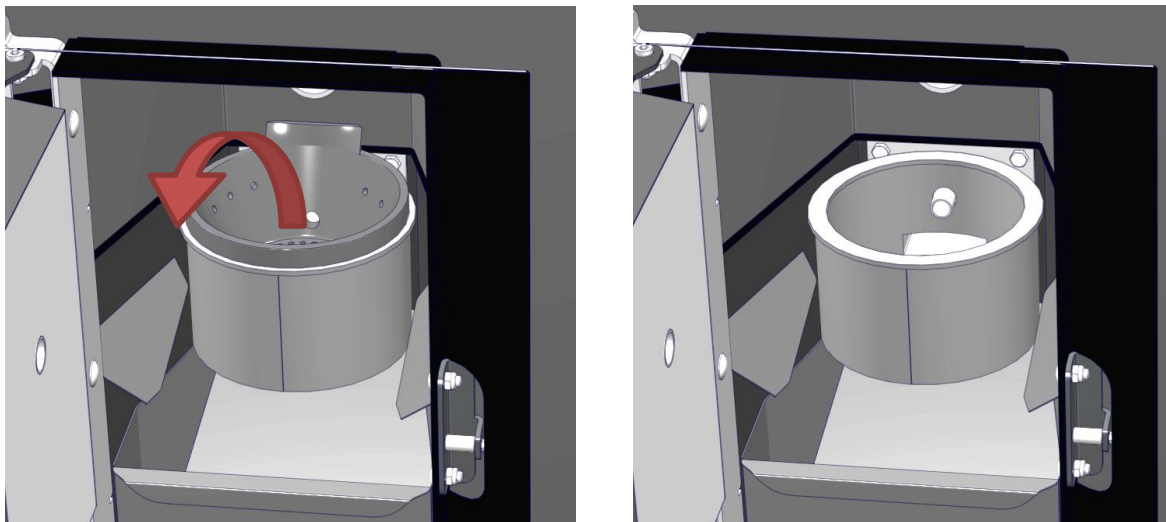

Weekly cleaning

- Turn the boiler off and wait until it has been cooled.
- Open the boiler door.
- Using the safety gloves take the ash pan out of the boiler and empty it into a fire-resistant container.
- Put the ash pan back into the firebox.
- Close the door before ignition



7.2 Cleaning the tube heat exchanger

i We recommend cleaning of heat exchange tubes before cleaning of ash pot and braizer basket

Turn the boiler off and wait until it has been cooled

1. Remove cover



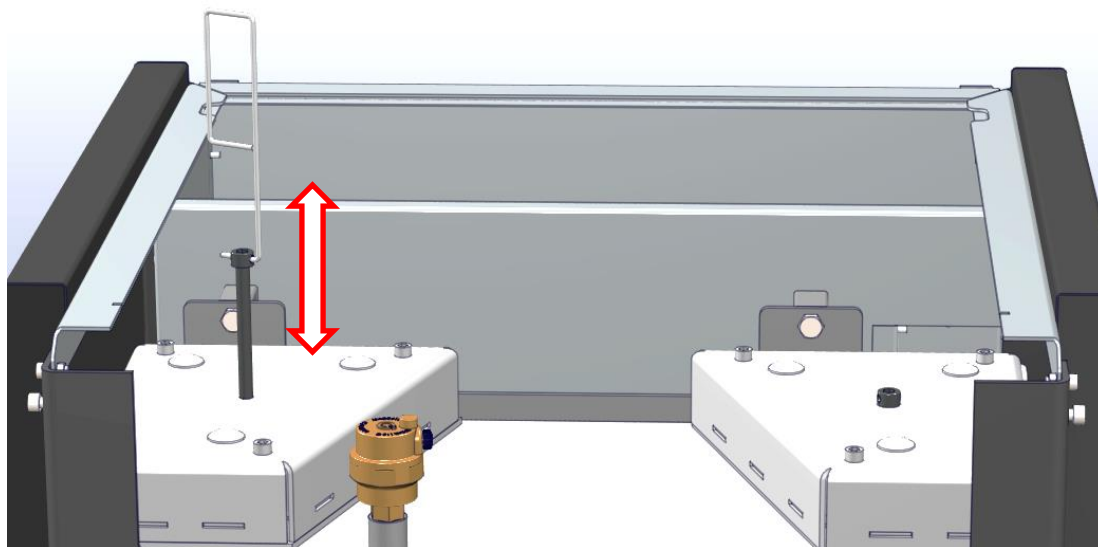

By moving UP-DOWN, we are cleaning ash depositions from tube exchanger.

Cleaning the ash

Inside of the firebox (behind of the ashbox) are one plate. Unscrew the screws and remove the cover. After that with the vacuum cleaner remove ash and sediments .

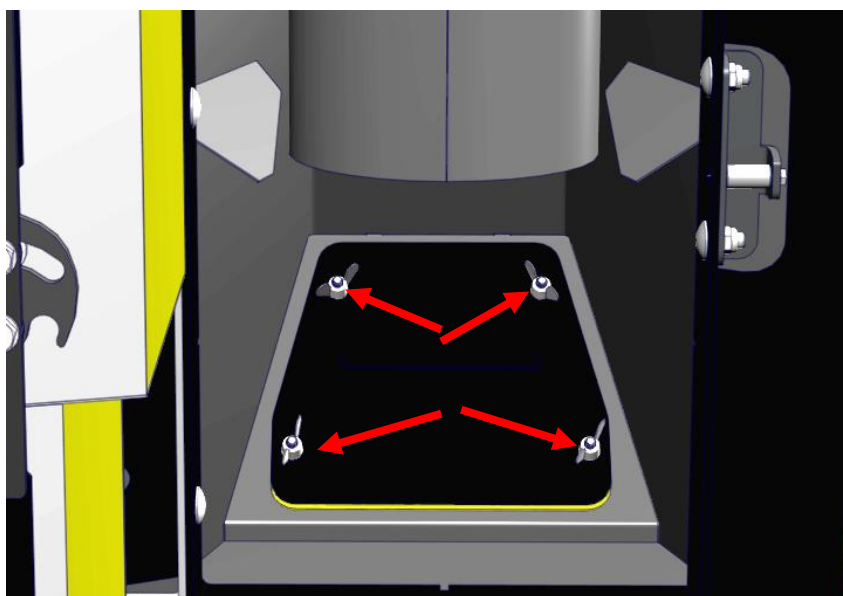

Also we need to clean fan plates from the ash layers.

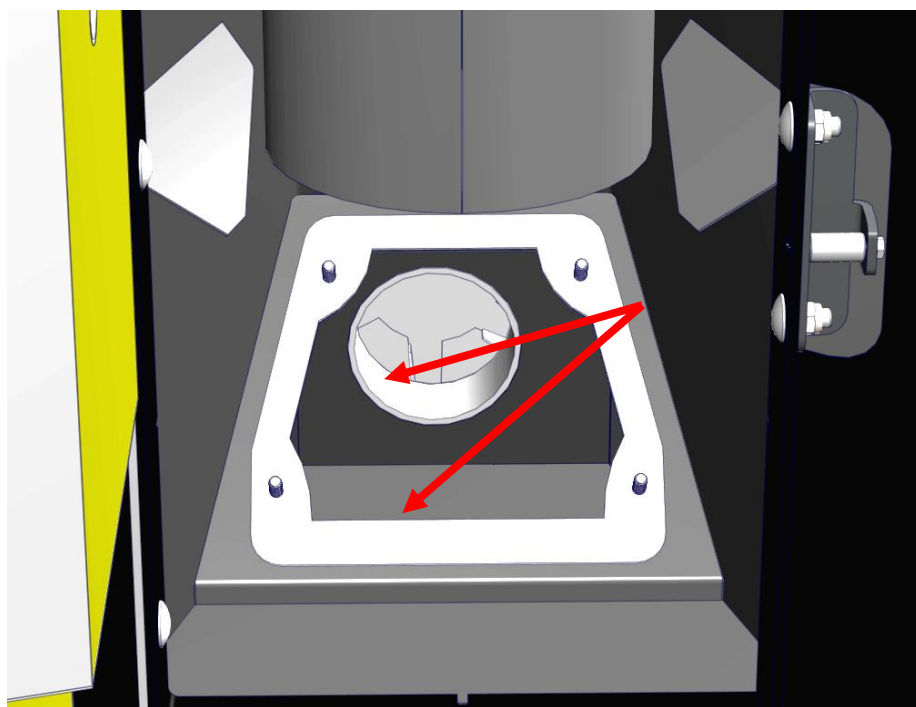

After cleaning, all components should be returned to their place

- Close the door before lighting a fire.
- Check if there is any ash left in the firebox or in the ash pan and clean them in accordance with the instructions given in paragraphs which refer to cleaning the ash pan and cleaning the firebox.

Removing side panels

If it is necessary to remove the side panels (in the case of cleaning the flue pipes, unblocking the circulation pump, etc.) the procedure is as follows:

- Remove screws from the back (IMBUS M5)

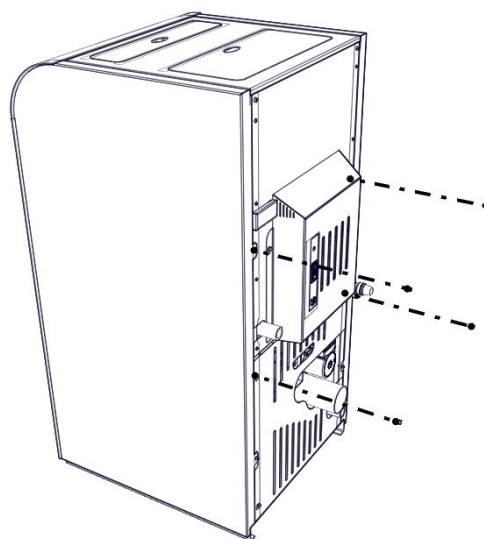

- Pull panel back 20 mm (1) , then pull up and remove (2). It is same way for removing the other side

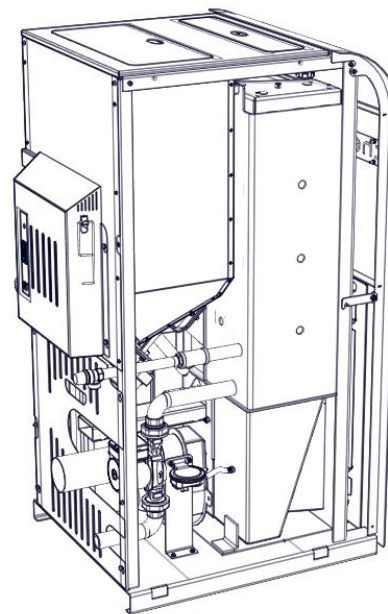
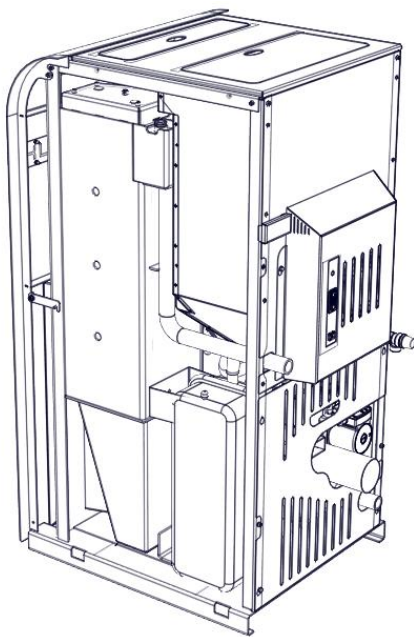
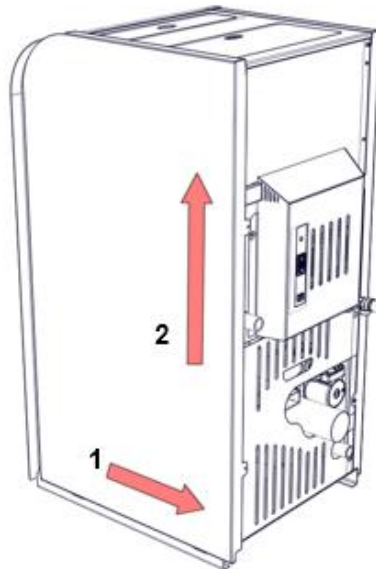

8 Connection options

8.1 Hydraulic schemes

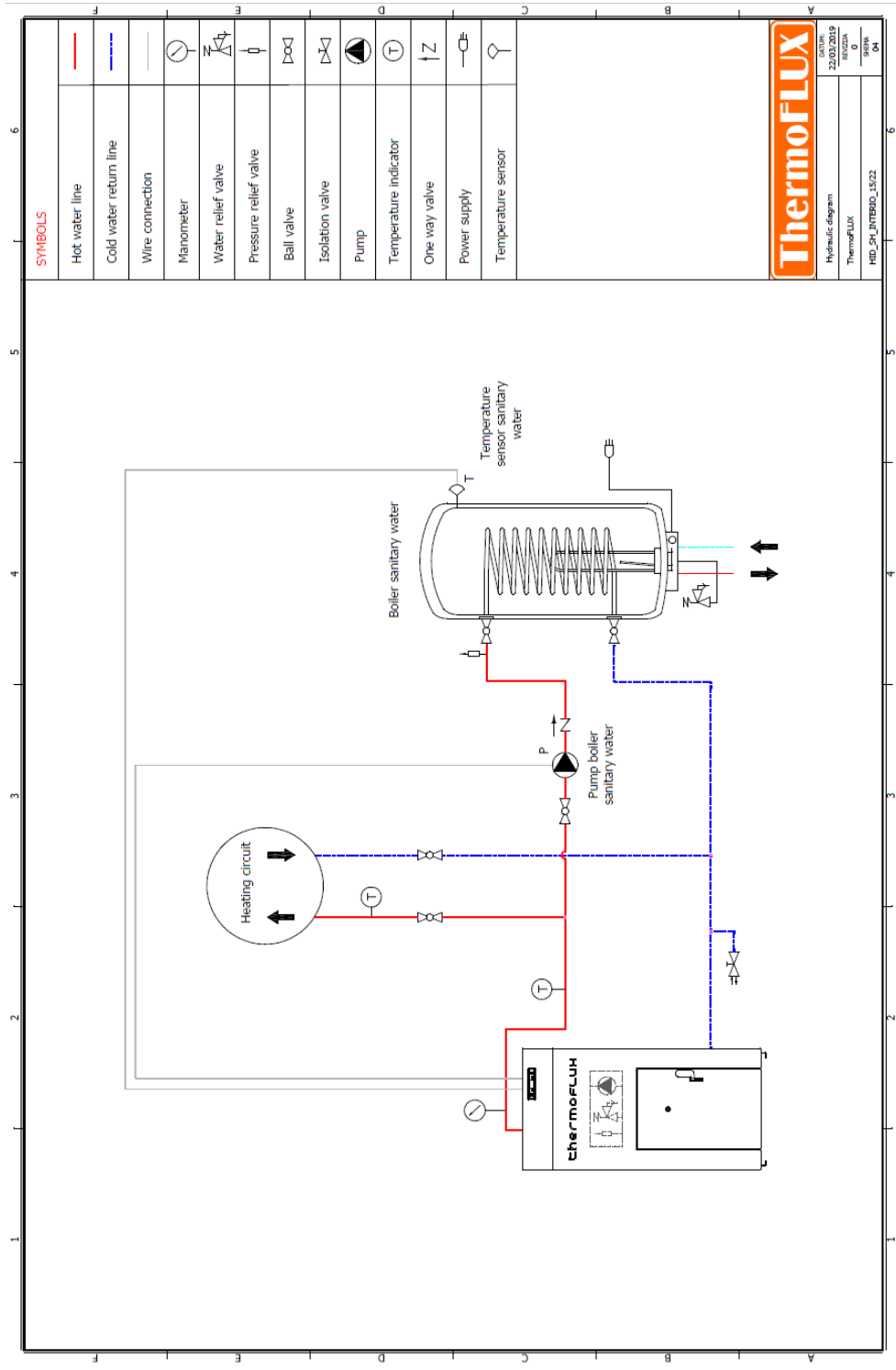

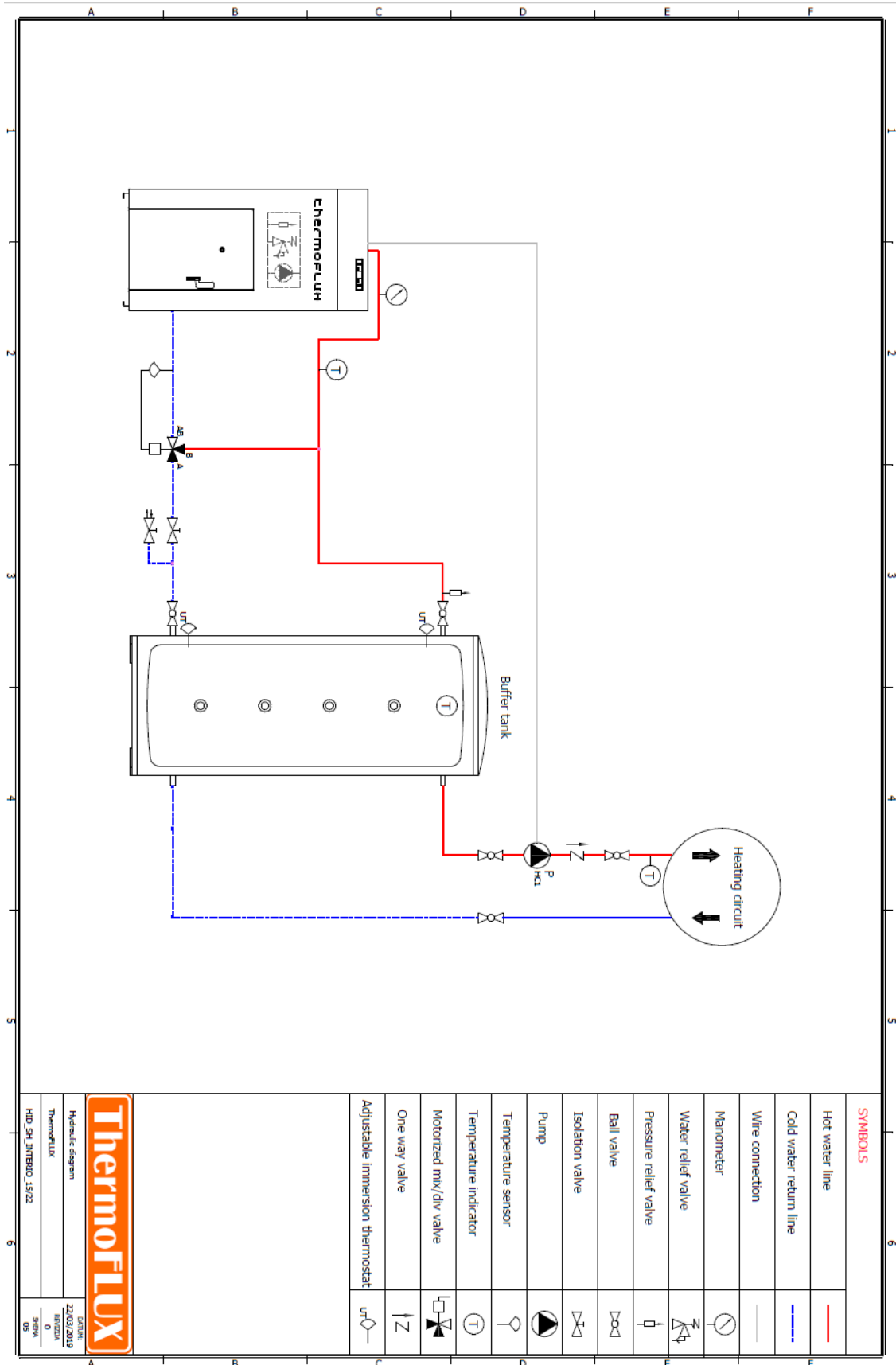

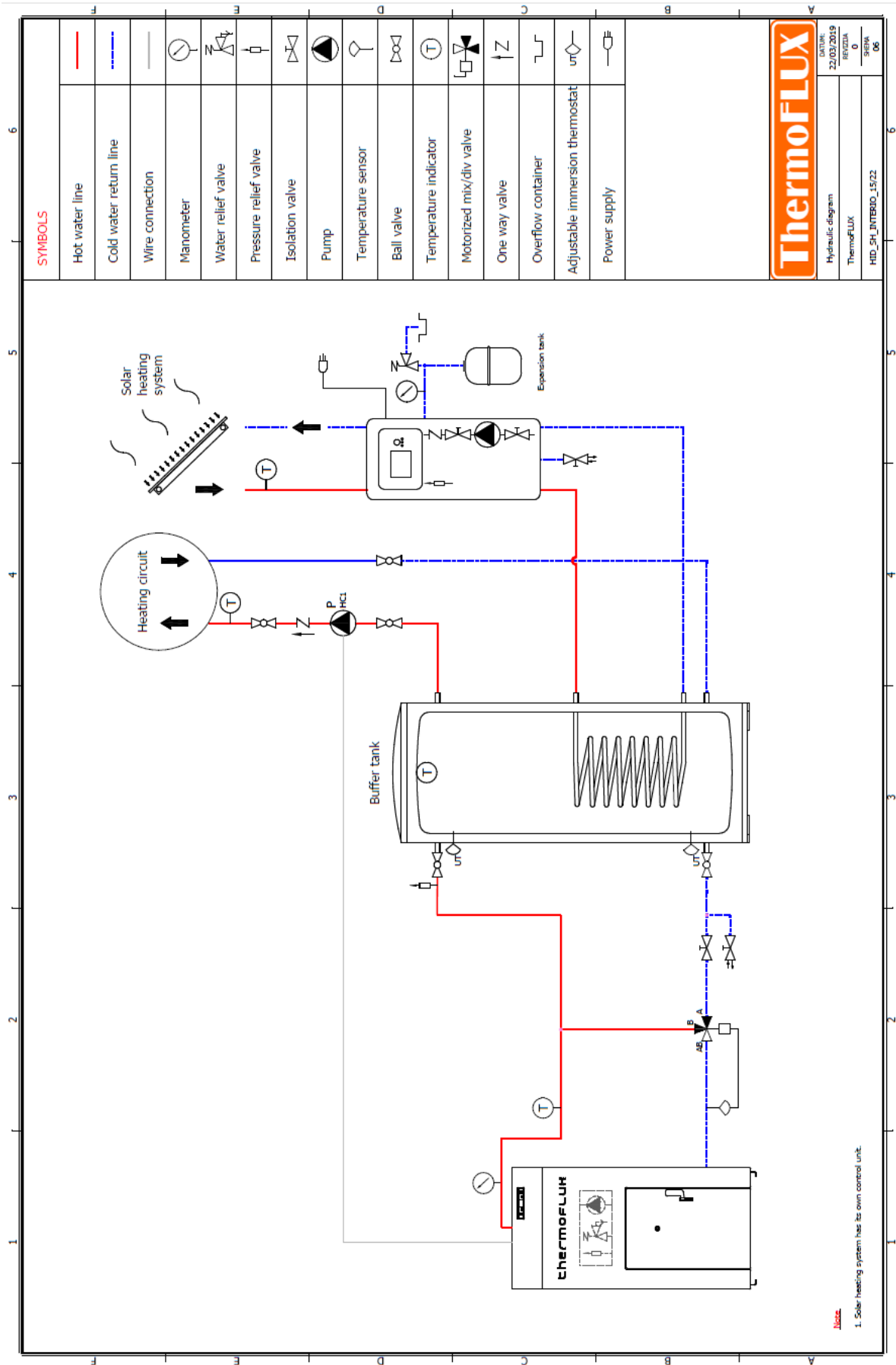

8.2 Scheme for electric connection

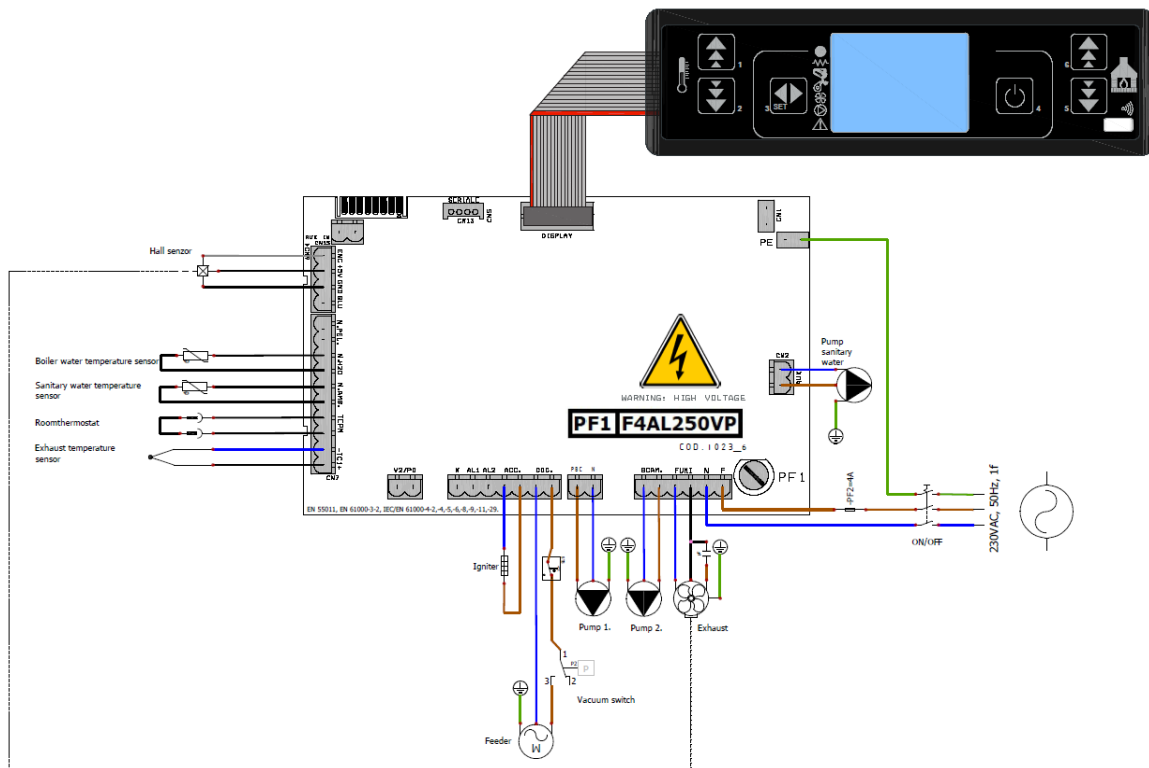

On the back side of the silo there is connection box for :

- Power 220 V, 50 Hz
- Room thermostat



Boiler needs to be connected to el. Power supply 220 V and 50 Hz, through fuse of 6 – 10 A (fast).

Room thermostat

User has possibility to instal room thermostat in other room separate from the boiler. Instalation and connection of the room thermostat should be performed only by authorized repairman.

9 Alarms

If faults occur in the heating system, it is possible to fix some of them by following these instructions.

Display	Description	Solution
	Alarm active- indicated next to the sign for alarm	Cancel the alarm can be executed by pressing the button 4  . After that, the display lists FINAL CLEANING lasting 4 minutes. After that we can restart the boiler if we solve the problem.
NO IGNITION	Failed ignition.	No pellets in the silo - fill the pellets in a silo Dosage spiral empty - initial filling A foreign object stuck dosage spiral - clean Poor quality pellets (wet pellet, long pellets, dust into pellets) - change the type of pellets Pellet igniter is defective - replace it Contact Service Restart the boiler.
NO PELET	During operation of the boiler, flue gas temperature has decreased below the permitted values	No pellets in the silo - fill the pellets in a silo Dosage spiral empty - initial filling A foreign object stuck dosage spiral - clean Poor quality pellets (wet pellet, long pellets, dust into pellets) - change the type of pellets Call service
SMOKE PROBE	Flue gas temperature sensor is defective or not connected. Boiler lists alarm is active and goes off.	Call service
WATER PROBE	Water temperature sensor is faulty or not connected Boiler lists alarm is active and goes off.	Call service
HOT FUMI	Flue gas temperature is above the allowed (250 ° C). Boiler lists alarm is active and goes off.	The boiler has not been cleaned, smoke sensor is dirty. Clean boiler and restart the ignition.

		Excessive amounts of feed pellets. Call service
SAFETY THERMAL	Safety thermostat (STB) has been activated because the boiler water temperature exceeded 95 °C.	Wait for the boiler to cool down and then unscrew the plastic cap and suitable tool to reset the switch. *see picture page 15* It is possible that the pump is out of service and there is no water circulation Call service.
BLACK OUT	The boiler is out of power	Reset alarm and start again

10 Instruction about safety removal and proper disposal of boiler

10.1 Disposal

Following elements are made of metal and can be disposed on landfills for metal:

- boiler
- cover metal sheets
- feeding system (except motor)
- braizer basket

Electronic components can be recycled .

Glass, glass wool and plastic parts can be recycled on landfills.

Motor auger is made of few types of material which can be recycled.



Oil and capacitors can be disposed only in special waste disposal sites.

11 Guarantee

11.1 Guarantee period

Guarantee period of 5 years applies on boiler body, metal covers and silo for pellet, and 2 years on electric component (regulation, motor, ignitier)

ThermoFLUX d.o.o. is responsible for service in BiH during guarantee period for failures as described in paragraph related to terms for guarantee,

Guarantee in other states is to be provided by authorised importer-distributor.

11.2 Guarantee terms

First start up of the boiler needs to be done by authorised service, or person authorised by ThermoFLUX or authorised importer – distributor.

Boiler must work in accordance with terms and conditions given in this manual.

Boiler needs to be instaled in accordance with all state regulations and law terms.

Quality of pellet must comply with all stnadards given in this manual.

11.3 Exemption from the guarantee

Guarantee does not cover:

- Unauthorised and negligent handling and maintenance
- Unauthorised opening and servicing of the boiler
- Improper installation, mechanical damage
- Damages caused by non-complying with instructions given in manual

Damages caused by other conditions such are: fire and water, high voltage, thunderstroke.

12 **Technical personal**



List of technical personal and authorised distributors you can find on our web pages : www.thermoflux.ba and www.servis.thermoflux.ba

ThermoFLUX d.o.o.
Bage br.3, Jajce
Bosnia and Hercegovina
Tel +387-30-657-100
www.thermoflux.ba

INTERIO 15/ 22 2019

